

## MITTATAULUKOT

### JOKASÄÄNTAKKI, MIESTEN MALLI

	XS	S	M	L	XL	XXL	XXXL
	46	48	50	52	54	56	58-60
A ½ Rinta	53	56	59	62	66	70	74
C ½ Helma	50	53	56	59	63	67	71
E ½ Hiha-aukko	34	35	36	37	38	39	40
F ½ Hais	27,5	28,5	29,5	30,5	21,5	32,5	33,5
G ½ Kädentie	10	11	11,5	12	12,5	13	13,5
H Hihan pituus	88	90	92,5	95	97,5	100	102,5
I Takapituus niskasta	73	75	77	79	81	83	85
K Etupituus olasta	69	71	73	75	77	79	81

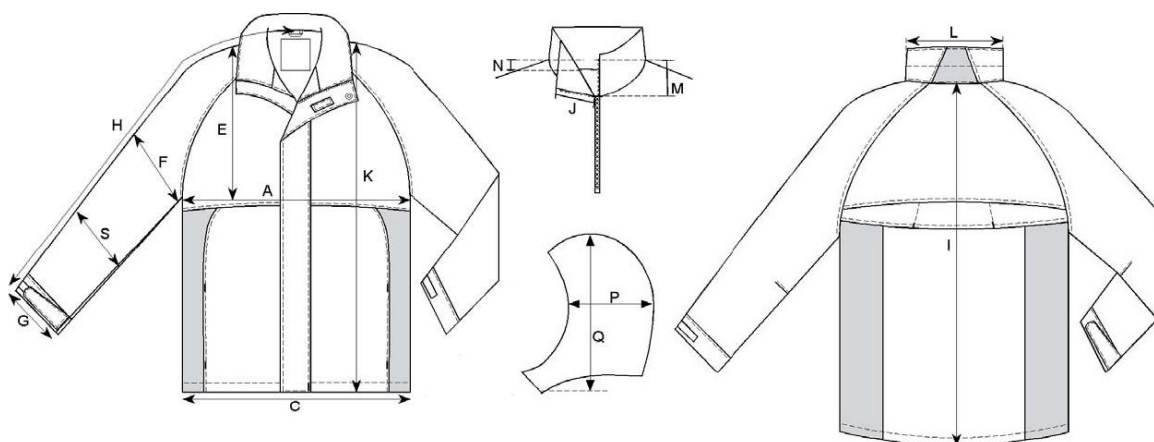

### JOKASÄÄNTAKKI, NAISTEN MALLI

	S	M	L	XL	XXL
	36	38	40	42	44-46
A ½ Rinta	52	55	58	61	65
B ½ Vyötärö	47	50	53	56	60
C ½ Helma	51	54	57	60	64
F ½ Hais	21,5	22	23	24	25
G ½ Kädentie	12	13	14	14	15
H Hihan pituus	82	83,5	85	87,5	89
I Takapituus niskasta	64	66	68	70	72
K Etupituus olasta	71	73	75	77	79

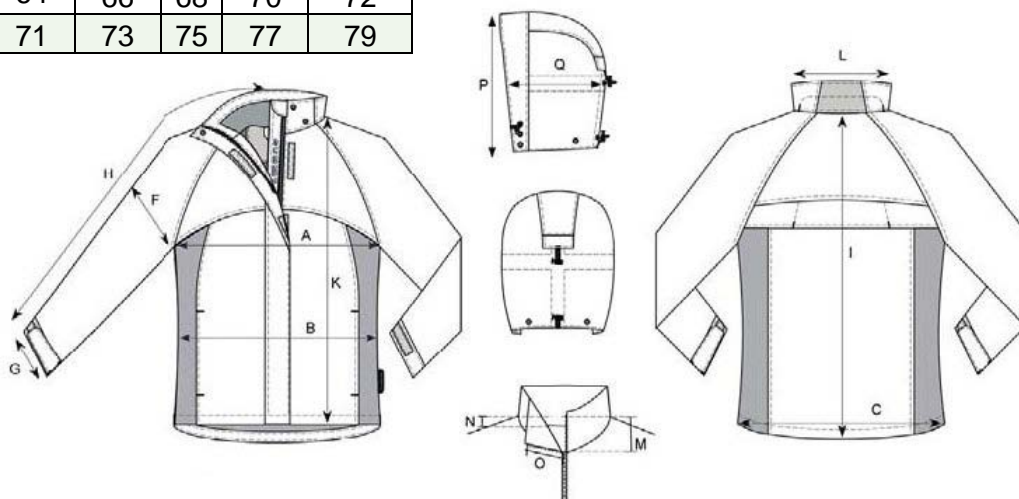

## MITTATAULUKOT

### SOFT SHELL -LIIVI, MIESTEN MALLI

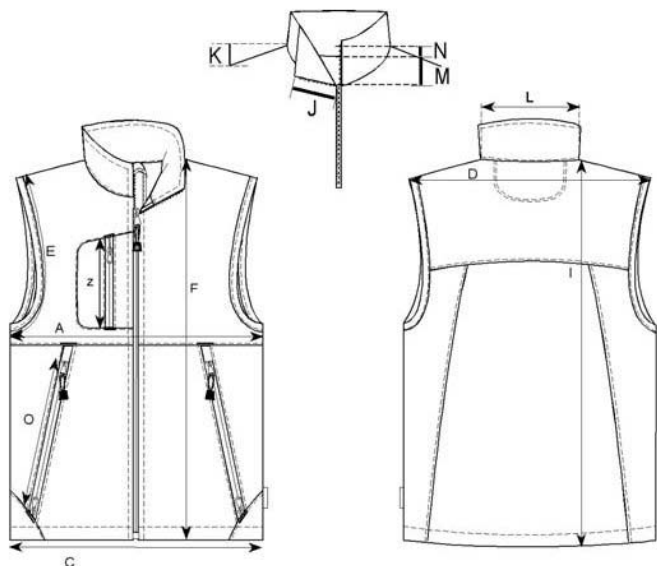

A ½ Rinta
C ½ Helma
I Takapituus niskasta
K Etupituus olasta

S	M	L	XL	XXL
48	50	52	54	56-58
52	55	58	61	65
50	53	56	59	63
71	73	75	77	79
67	69	71	73	75

### SOFT SHELL -LIIVI, NAISTEN MALLI

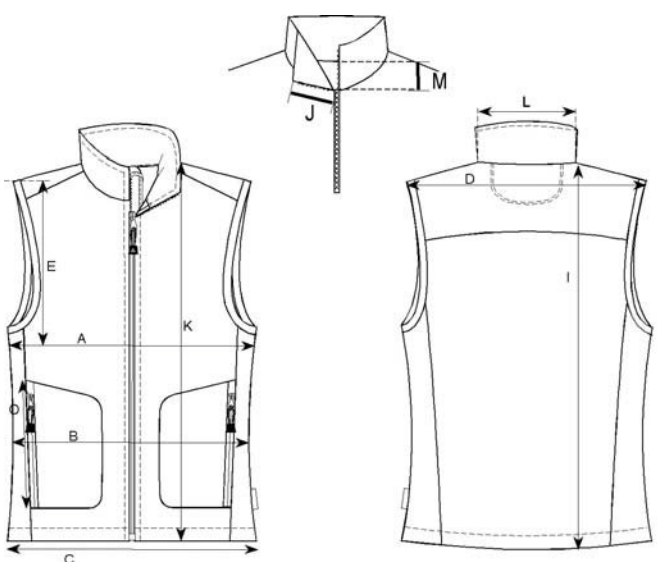

A ½ Rinta
B ½ Vyötärö
C ½ Helma
I Takapituus niskasta
K Etupituus olasta

S	M	L	XL	XXL
36	38	40	42	44
48	51	54	57	61
45	48	51	54	57
49	52	55	58	62
64	66	68	70	72
61	63	65	67	69

## MITTATAULUKOT

### COLLEGE-TAKKI, MIESTEN KOOT

A Body pituus
B ½ Rinta
C ½ Helma venyttämättä
D Olkaleveys
F ½ Haisu
G Hihan pituus
H ½ Resorin leveys
I Päätie

S	M	L	XL	XXL
69	71	73	75	77
52	55	58	62	66
39	42	45	49	53
48	50	52	54	56
24	25	26	27	28
64	65	67	68,5	70
10	10,5	11	11,5	12
19	19,5	20	20,5	21

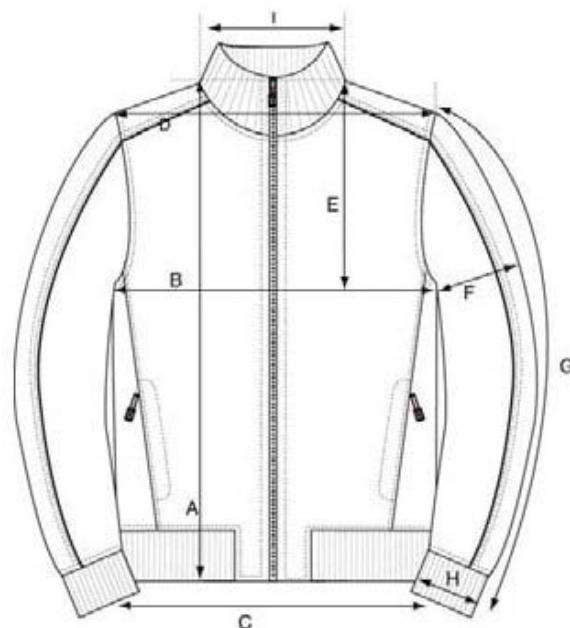

### COLLEGE-TAKKI, NAISTEN KOOT

A Body pituus
B ½ Rinta
C ½ Helma venyttämättä
D Olkaleveys
F ½ Haisu
G Hihan pituus
H ½ Resorin leveys
I Päätie

S	M	L	XL	XXL
36	38	40	42	44
63	65	67	69	71
50	52	54	57	60
38	40	42	45	48
41	42	43	44	45
20	21	22	23	24
60	61	62	63	64
9,5	10	10,5	11	11,5
17,5	18	18,5	19	19,5

